

# Wall mounted electric storage water heater EVS 15L to 150L





# Wall mounted electric storage water heater EVS 15L to 150L

> New vertical storage water heaters / Product











# Wall mounted electric storage water heater EVS 15L to 150L

> New vertical storage water heaters / Packaging

<b>STIEBEL ELTRON</b> Storage Water Heater EVS 30		<b>STIEBEL ELTRON</b> Storage Water Heater EVS 30	
<b>STIEBEL ELTRON</b> 30L Storage Water Heater	<b>STIEBEL ELTRON</b> 30L Storage Water Heater	<b>STIEBEL ELTRON</b> 30L Storage Water Heater	<b>STIEBEL ELTRON</b> 30L Storage Water Heater
	 EVS 30		 EVS 30

# Wall mounted electric storage water heater EVS 15L to 150L

> New vertical storage water heaters / Packaging Dimensions

 Storage Water Heater EVS 30		 Storage Water Heater EVS 30	
 30L Storage Water Heater	 30L Storage Water Heater	 30L Storage Water Heater	 30L Storage Water Heater
		 EVS 30	

EVS	15	30	50	80	100	150
Packaging	375*375*595	430*430*665	465*465*820	545*545*845	545*545*980	545*545*1330

# Wall mounted electric storage water heater EVS 15L to 150L

## > Simple Operation

- > Continues variable temperature selection
- > Longevity
- > Vertical Orientation
- > Thermometer display
- > Indicator lights
- > Safety Valve



# Wall mounted electric storage water heater EVS 15L to 150L

## > Established Technology

- > Pressurized inner enameled steel tank
- > Magnesium protection anode
- > Electronic leakage circuit breaker (ELCB)
- > Safety temperature limiter
- > Incoloy heating element
- > 32.5 to 25 mm thick insulation layer



# Wall mounted electric storage water heater EVS 15L to 150L

## > Dimensions

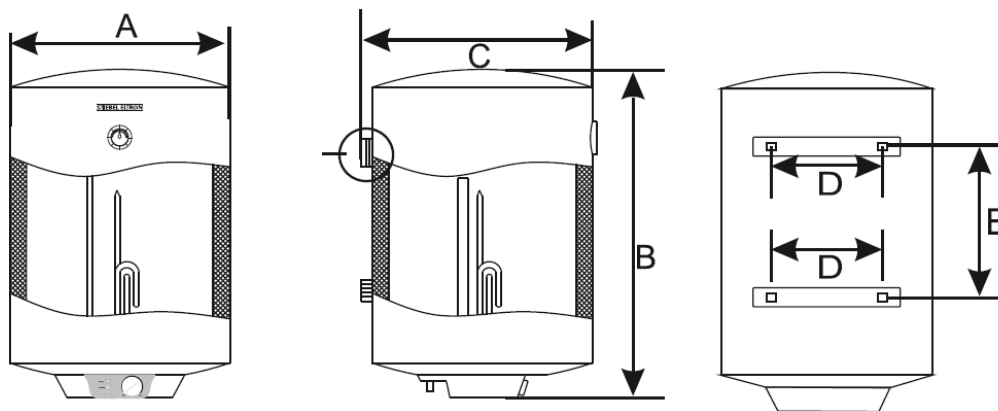

EHS	15	30	50	80	100	150
A	305	365	390	460	460	460
B	543	615	745	740	880	1230
C	337	390	415	485	485	485
D	170	198	198	198	198	198
E	-	-	-	-	417	767

# Wall mounted electric storage water heater EVS 15L to 150L

## > Technical Data

Type	EVS	15	30	50	80	100	150
Rated Voltage	V	220-240	220-240	220-240	220-240	220-240	220-240
Rated Power @220V	W	1500	2000	2000	2000	2000	2000
Capacity	L	15	30	50	80	100	150
Heating Element		Incoloy	Incoloy	Incoloy	Incoloy	Incoloy	Incoloy
Temperature	°C	15 to 75	15 to 75	15 to 75	15 to 75	15 to 75	15 to 75
Net Weight	kg	10.80	12.60	17.10	23.30	27.60	34.90
Working Pressure	MPa	0.70	0.70	0.70	0.70	0.70	0.70
Insulation	mm	32.5	32.5	25	25	25	25
Protection		IPX4	IPX4	IPX4	IPX4	IPX4	IPX4
Approval		CB	CB	CB	CB	CB	CB



# Wall mounted electric storage water heater EVS 15L to 150L

## > Configuration

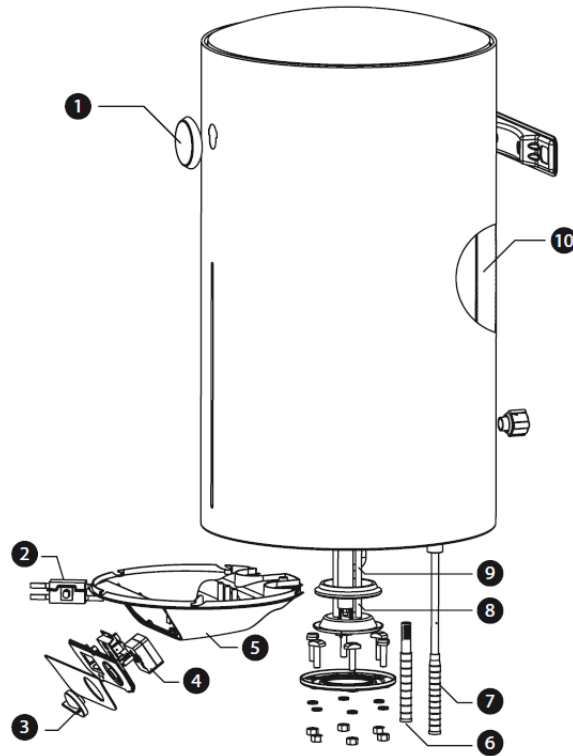

1	Thermometer
2	Limiter
3	Temperature control knob
4	Thermostat
5	Bottom cover
6	Inlet pipe
7	Outlet pipe
8	Magnesium anode
9	Incoloy heating element
10	High quality insulation

# Wall mounted electric storage water heater EVS 15L to 150L

## > Arguments at a glance

- > Plastic covers and metal jacket
- > Single heating function
- > Manual control
- > Vitreous enamel coating inner tank
- > Corrosion and acid resistance
- > Non-fluorine polyurethane insulation layer (32.5 – 25 mm)
- > Protection against dry heating
- > Protection against over temperature
- > Protection against electric leakage
- > Temperature up to 75 °C
- > **For indoor installation only**