

Wall mounted electric storage water heater EHS 15L to 150L

Wall mounted electric storage water heater EHS 15L to 150L

> New horizontal water storage heaters / Product



EHS	15	30	50	80	100	150
-----	----	----	----	----	-----	-----

Wall mounted electric storage water heater EHS 15L to 150L

> New horizontal water storage heaters / Packaging

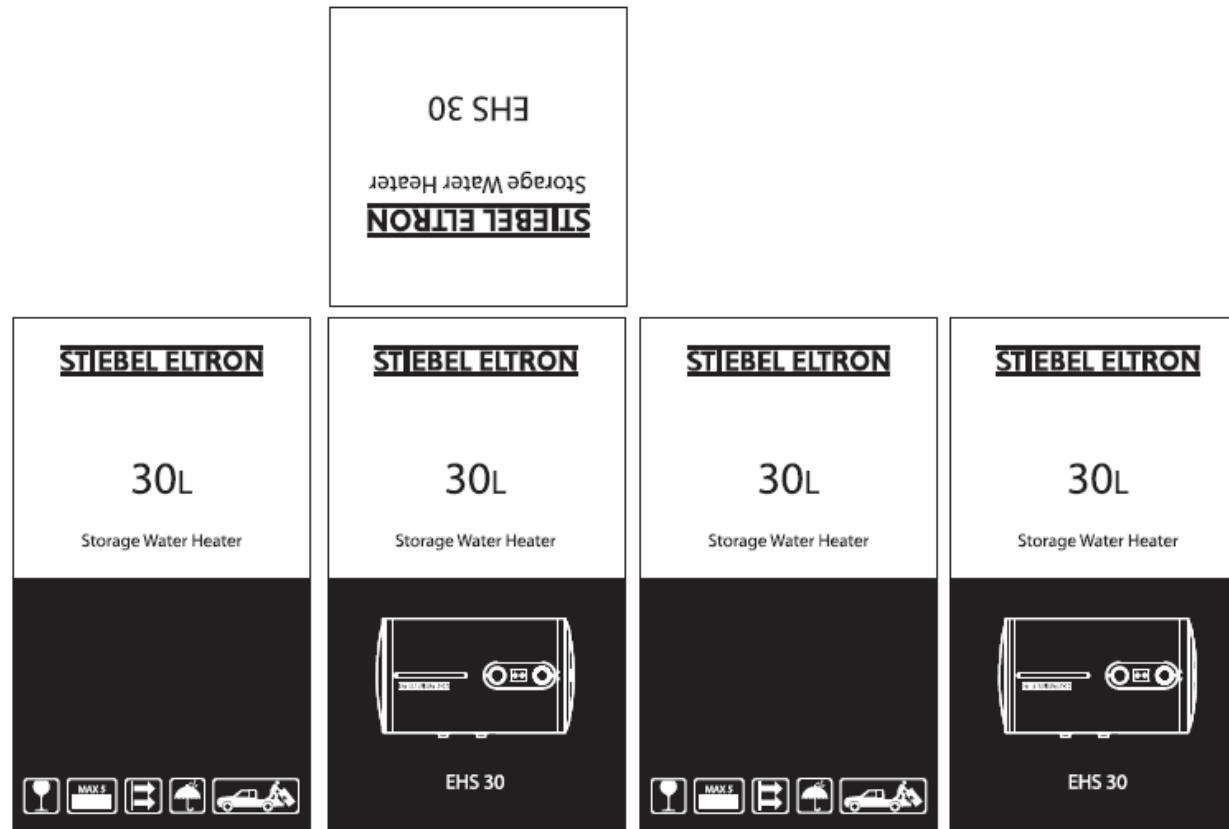

Wall mounted electric storage water heater EHS 15L to 150L

> New horizontal water storage heaters / Packaging Dimensions

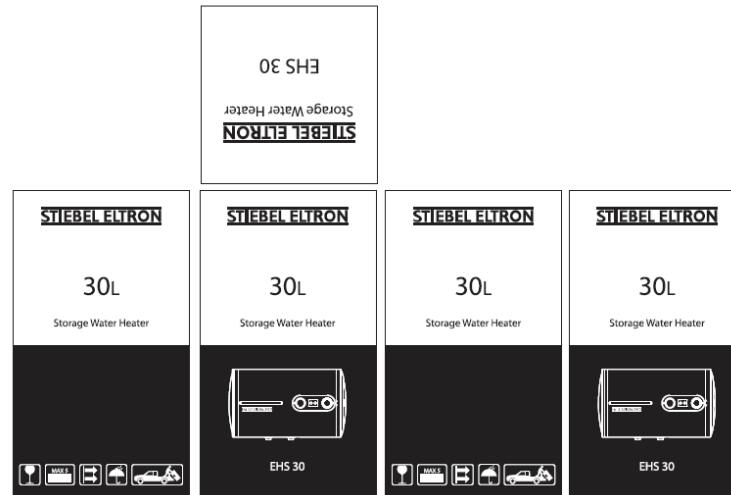

EHS	15	30	50	80	100	150
Packaging	390*390*650	450*450*740	485*485*845	555*555*905	565*565*1050 (with collet)	575*575*1355 (with collet)

Wall mounted electric storage water heater EHS 15L to 150L

> Simple Operation



- > Continues variable temperature selection
- > Longevity
- > Easy access for maintenance
- > Thermometer display
- > Indicator lights
- > Safety Valve

Wall mounted electric storage water heater EHS 15L to 150L

> Established Technology



- > Pressurized inner enameled steel tank
- > Magnesium protection anode
- > Electronic leakage circuit breaker (ELCB)
- > Safety temperature limiter
- > Incoloy heating element
- > 35 mm thick insulation layer

Wall mounted electric storage water heater EHS 15L to 150L

> Dimensions

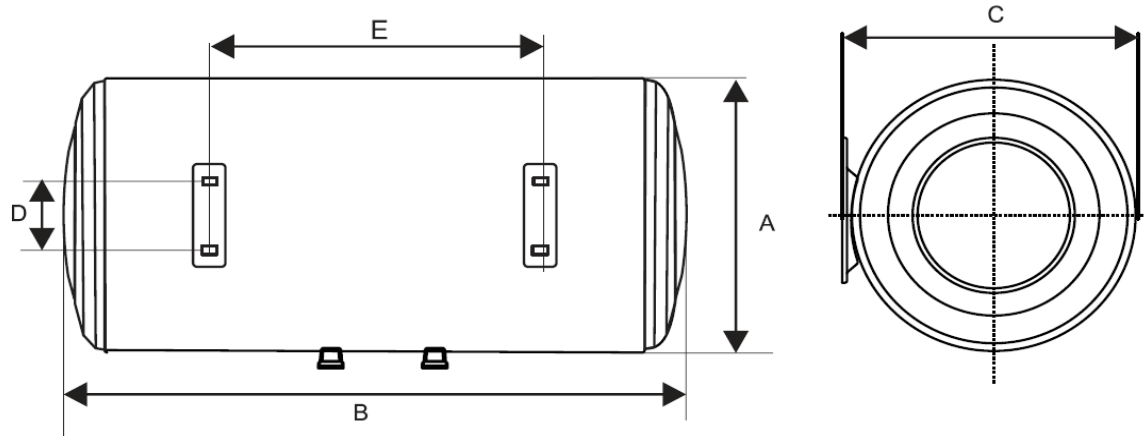

EHS	15	30	50	80	100	150
A	310	370	410	480	480	480
B	562	649	749	826	974	1294
C	330	385	425	495	495	495
D	164	204	204	204	204	204
E	116	177	310	297	447	767

Wall mounted electric storage water heater EHS 15L to 150L

> Technical Data

Type	EHS	15	30	50	80	100	150
Rated Voltage	V	220-240	220-240	220-240	220-240	220-240	220-240
Rated Power @220V	W	1500	2000	2000	2000	2000	2000
Capacity	L	15	30	50	80	100	150
Heating Element		Incoloy	Incoloy	Incoloy	Incoloy	Incoloy	Incoloy
Temperature	°C	15 to 75	15 to 75	15 to 75	15 to 75	15 to 75	15 to 75
Net Weight	kg	9.7	13.2	17.5	23.7	27.8	37.6
Working Pressure	MPa	0.7	0.7	0.7	0.7	0.7	0.7
Insulation	mm	35	35	35	35	35	35
Protection		IPX4	IPX4	IPX4	IPX4	IPX4	IPX4
Approval		CE/CB	CE/CB	CE/CB	CE/CB	CE/CB	CE/CB

Wall mounted electric storage water heater EHS 15L to 150L

> Configuration

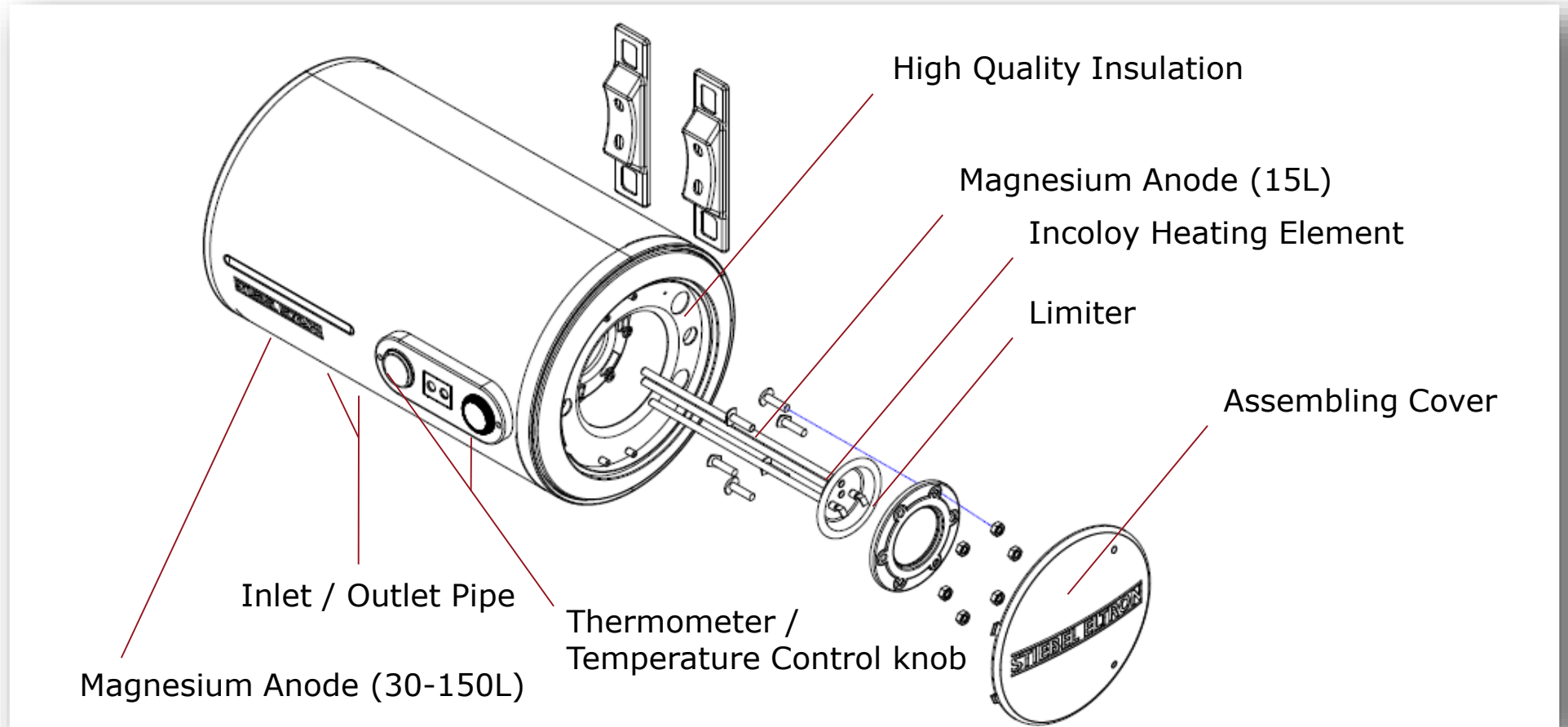

Wall mounted electric storage water heater EHS 15L to 150L

> Arguments at a glance

- > Plastic covers and metal jacket
- > Single heating function
- > Manual control
- > Vitreous enamel coating inner tank
- > Corrosion and acid resistance
- > Non-fluorine polyurethane insulation layer (35mm)
- > Protection against dry heating
- > Protection against over temperature
- > Protection against electric leakage
- > Temperature up to 75 °C
- > **For indoor installation only**